

2MP Network IR Mini Bullet Camera

IPC2122SR3 Series



Key Features

Optics

- Day/night functionality
- Smart IR , up to 30 m (98 ft) IR distance
- Optical glass window with higher light transmittance
- IR anti-reflection window to increase the infrared transmittance
- 3D DNR (Digital Noise Reduction)

Compression

- H.264/MJPEG
- Triple streams
- 9:16 corridor format

Network

- ONVIF Conformance

Structure

- Wide temperature range: -35°C to 60°C (-31°F to 140°F)
- Wide voltage range of $\pm 25\%$
- IP66

Specifications

	IPC2122SR3-PF36	IPC2122SR3-PF60	IPC2122SR3-PF120
Camera			
Sensor	1/2.8", 2.0 megapixel, progressive scan, CMOS		
Lens	3.6mm@F1.8 Angle of view(H): 80.5°	6.0mm@F1.8 Angle of view(H): 49.9°	12.0mm@F1.8 Angle of view(H): 25.8°
Shutter	Auto/Manual, 1/6~1/8000 s		
Min. Illumination	Colour: 0.06 Lux (F1.4, 50IRE) 0 Lux with IR on		
Day/Night	IR-cut filter with auto switch (ICR)		
IR Range	Up to 30m (98 ft) IR range		
S/N	>52dB		
WDR	Digital		
Noise Reduction	2D/3D		
Video			
Max. Resolution	1920×1080		
Video Compression	H.264/MJPEG		
Frame Rate	1080P (1920*1080): Max. 30 fps; 720P (1280*720): Max. 30 fps; D1 (720*576): Max. 25 fps		
Video Streaming	Triple		
9:16 Corridor Mode	Supported		
ROI	Supported		
OSD	Up to 8 OSDs		
Motion Detection	Up to 2 areas		
Privacy Mask	Up to 4 areas		
Network			
Protocols	IPv4,IGMP,ICMP,ARP,TCP,UDP,DHCP,RTP,RTSP,DNS,DDNS,NTP,FTP,UPnP,HTTP		
Compatible Integration	ONVIF		
Interface			
Network	1 RJ45 10M/100M Base-TX Ethernet		
General			
Power	12 V DC, or PoE (IEEE802.3 af)		
	2.0 W (6.4 W with IR on)		
Dimensions (L × W × H)	157.3 × 62.4 × 63 mm (6.2" × 2.5" × 2.5")		
Weight	0.45 kg (0.99 lb)		
Working Environment	-35°C ~ +60°C (-31°F ~ 140°F), Humidity ≤ 90% RH(non-condensing)		
Ingress Protection	IP66		

Dimensions

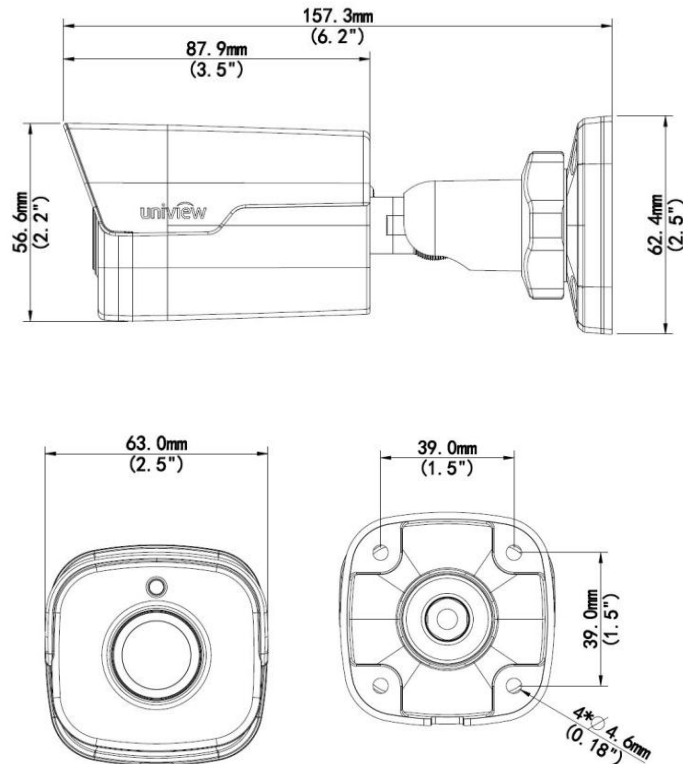

Accessories

Installation mode	Accessories	Description
Wall mount	Mounting pedestal is included in the Product package	
Ceiling mount	Mounting pedestal is included in the Product package	

Zhejiang Uniview Technologies Co., Ltd.

Building No.10, Wanlun Science Park, Jiangling Road 88, Binjiang District, Hangzhou, Zhejiang, China (310051)

Email: overseasbusiness@uniview.com; globalsupport@uniview.com

<http://www.uniview.com>

©2015 Zhejiang Uniview Technologies Co., Ltd. All rights reserved.

*Product specifications and availability are subject to change without notice.